

## USING THE EF400 AND EF1210 WITH AUTOMATIC MICROPHONE MIXERS

The combination of ASPI Digital echo cancellers and automatic microphone mixers can make very powerful and economical conferencing systems. Conferencing systems of any size and function can be designed using a combination of automatic mixers and ASPI Digital products.

This document describes the recommended configurations of systems using ASPI Digital echo cancellers and automatic microphone mixers. The EF400 is compatible with all automatic mixers. The EF1210 easily interfaces to all automatic mixers that accept line level inputs, and can work with mic level inputs (with pads).

### DESIGNING THE ROOM

The EF400 and EF1210 are designed to provide maximum flexibility in the design of the sound system. The system can be designed almost as if the echo cancellation were not there. For instance, the design for a boardroom with zoned reinforcement should not change depending on whether it will have conferencing capabilities. You can design the system around the features and functionality of the automatic mixers and other equipment, and then place the echo canceller right after the mics (in the case of the EF1210), or right in front of the codec (in the case of the EF400). Sample block diagrams of different types of systems are described below and shown in Figure 1.

#### EF1210 - No Sound Reinforcement

When using the EF1210, one EF1210 is needed for each automatic mixer. The mixers may be linked, and the output of the mixers is sent directly to the video codec. The output of the codec should be sent to all EF1210s as an AEC reference. The zone output of one of the EF1210s can be used to provide the remote audio to the amplifier and loudspeakers.

#### EF400 - No Sound Reinforcement

When using the EF400 with automixers, simply connect the output of the mixer to the mic/line input of the EF400. If multiple mixers are used, they can be linked together. Only one EF400 is needed for the system, regardless of how many mixers are used. The remote output of the EF400 is sent to the video codec.

#### EF1210 with Sound Reinforcement

When the EF1210 is used in a sound reinforcement system, the automatic mixers should still be linked, but set for “Local” linking. This causes the output of each mixer to contain only a mix of its own mics, while using the information from other mixers to adjust thresholds. If the automatic mixer does not allow for local linking, the mixers should not be linked. A matrix mixer (the size depends on how many mixers are used) can send the appropriate mix of microphones, program audio, and remote audio to each zone’s loudspeakers. A matrix with full crosspoint gain may be useful to provide different levels of reinforcement between different zones. The matrix should also provide a mix of all mics to the codec.

Note that the AEC reference inputs to the EF1210 do not include the reinforced speech for each zone. The AEC reference should only contain program audio and remote speech.

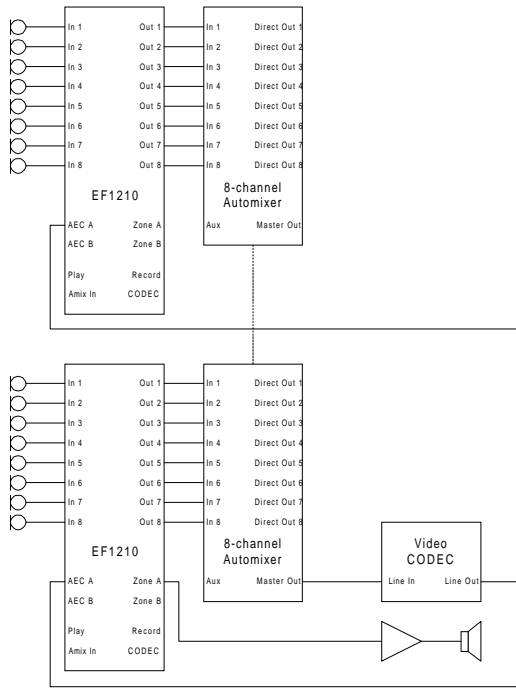

**Figure 1a:** EF1210 and eight channel mixers without sound reinforcement.

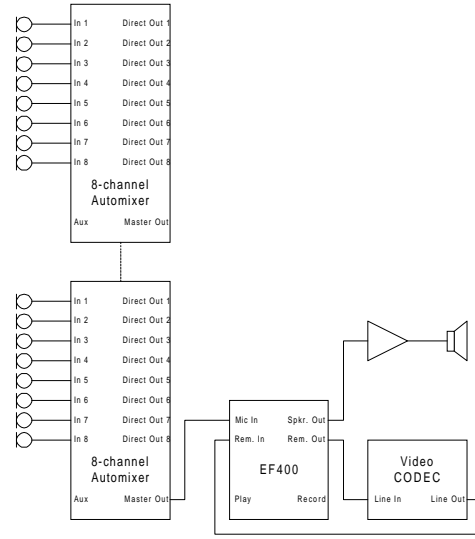

**Figure 1b:** EF400 and eight-channel mixers without sound reinforcement.

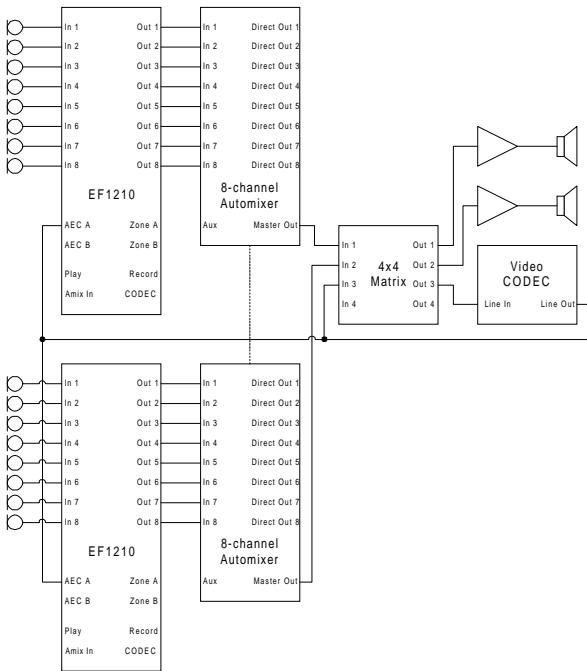

**Figure 1c:** EF1210 and eight-channel mixers with sound reinforcement.

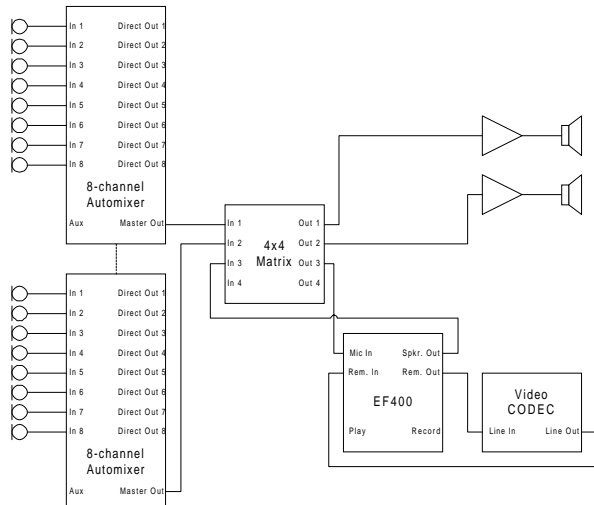

**Figure 1d:** EF400 and eight-channel mixers with sound reinforcement.

## EF400 with Sound Reinforcement

The configuration of a sound reinforcement and conferencing system with an EF400 is very similar to an EF1210 system. The only major difference is that the EF400 is placed between the matrix and the video codec, while the EF1210 is placed between the microphones and the mixers. The mixers should be set for “Local” linking mode in this type of system as well (or should not be linked if local linking is not an option). The matrix provides the appropriate mix of microphones, remote audio, and program audio to the loudspeakers and video codec.

## Splitting the EF1210

The EF1210 may be split into two separate rooms using the two AEC reference inputs. This may be used to provide an economical solution for two adjacent rooms, or for room combining applications. If the EF1210 is split equally, two four channel mixers may be used. If one of the rooms has more than four mics (say one room has 6 and the other has 2), one four-channel mixer and one eight-channel mixer may be used. The figure below shows how two four-channel mixers could be configured to split a single EF1210 between two totally independent rooms.

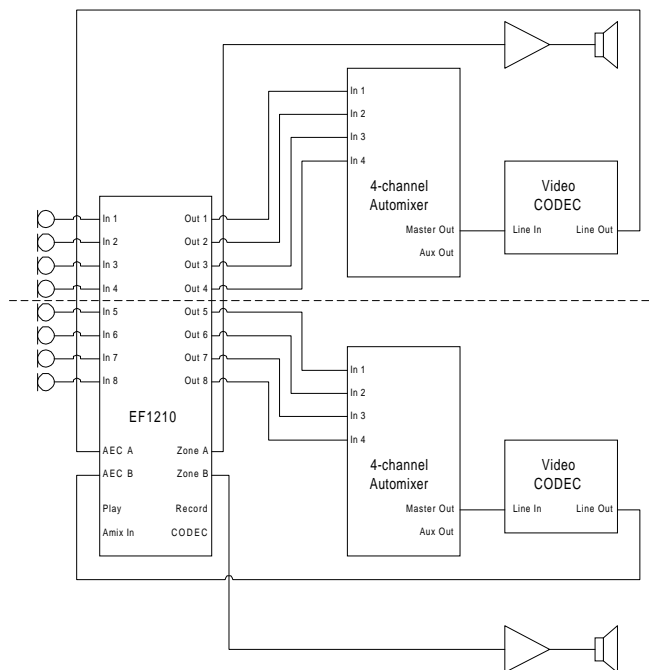

**Figure 2:** Using the EF1210 with 2 four-channel mixers for two different rooms.

It is possible to use the EF1210 in zoned reinforcement systems with less than 8 mics in each zone. In this case, however, it is not necessary to use both AEC reference inputs. All the echo cancellers should get the same reference, which is the remote speech and program audio. The sound reinforcement signals should not be used as part of the reference. Since all the channels are using the same reference, it is possible to send any channel to any mixer. For example, in a system with 16 mics and four zones, four four-channel mixers could be used with two EF1210s. In a larger system (24 mics with four zones), four eight-channel mixers could be used with three EF1210s. Six channels could be sent to each mixer. Because all the channels

are using the same reference, it doesn't matter that some mixers are getting channels from two different EF1210s.

## GETTING OPTIMUM ECHO CANCELLATION WITH THE EF400

Automatic mixers present a challenge to single channel echo cancellers. They effectively cause constant changes in the acoustic properties of the room by turning microphones on and off. The echo canceller must adapt quickly and constantly to keep up with these changes. This is the case when using an automatic mixer with the EF400. The EF400 adapts very quickly and therefore works better with automatic mixers than any other single channel echo canceller. However, some precautions may enhance the performance of the EF400 when used with an automatic mixer, especially in difficult rooms.

### Avoid Last Mic Lock-On

Last mic lock-on should be turned off (so that all mics are off after their hold time has expired). This is required in most situations for the EF400 to work properly.

### Use less off attenuation.

When off attenuation is infinite, the AEC sees no echo in the room when all of the microphones are off. When a mic is activated, there is suddenly a great deal more echo to cancel. Using a setting for 10-20 dB off attenuation makes these changes less drastic.

### Isolate microphones from loudspeakers.

Providing isolation between microphones and loudspeakers has two benefits. First, it reduces the echo received by the echo canceller, which makes its job easier. When using automatic mixers, it also makes the loudspeaker signal less likely to cause microphones to activate. This is important because it reduces the likelihood that random microphones will activate from the loudspeaker, changing the echo path while only the far end is talking. Reducing the number of microphone activations caused by the loudspeaker signal will improve the echo canceller's performance.

### Provide remote reference channel to mixer.

Many automatic mixers adjust thresholds when a channel is activated, so that only one microphone is gated per talker. This feature can be used to prevent the loudspeaker signal from activating microphones, if the mixer is designed so that a muted channel still affects thresholds. If an extra mixer channel is available, the remote (far end) signal can be fed to a line level input. This input should then be permanently muted, using logic connections or DIP switches. When the remote end talks, the muted channel will be activated. The threshold will increase and prevent other channels in the mixer from activating on the same signal, but will allow local speech in the room to activate microphones.

Since the EF1210 performs echo cancellation on the individual channels before mixing, it is not affected by the automatic mixer. Therefore, these precautions are not necessary (although it is always beneficial to provide good isolation between loudspeakers and microphones).

## SPECIAL EQUIPMENT AND APPLICATIONS

### Using Push-To-Talk Microphones

For optimal AEC performance, the push-to-talk switch should not mute the microphone element directly. Rather, it should provide a contact closure or TTL signal to the logic controls of the automatic mixer. If built-in switches are required, microphones such as the Shure MX392, Crown PCC-170SWO, and Beyerdynamic MPC67RC models are recommended. These provide a separate logic signal, but do not mute the microphone element directly when the switch is toggled. In many cases (such as with ceiling mounted mics), an external switch can be connected directly to the mixer's logic port. In general, the EF1210 will have the best performance with push-to-talk mics.

Alternatively, the mute functions on the EF1210 may be used to provide push-to-talk or other muting functionality through RS-232 control.

### Using Direct Outs

If direct outs of each microphone channel are needed for recording or other purposes, the EF1210 is recommended. Since the EF1210 provides echo cancellation on each channel, each of these direct outs will have the echo removed. The EF400 may be used, but the direct outs from the automatic mixer may have audible acoustic echo since the echo cancellation is performed after the mix.

### Dynamics Processing

A dynamics processing device (such as a compressor) may be useful for providing constant levels to and from the room. For instance, compression may be used on the output of a codec (or multiple codecs in a bridge) to provide consistent levels from various remote systems. A dynamics processor may be used with any combination of EchoFree echo cancellers and automatic mixers.

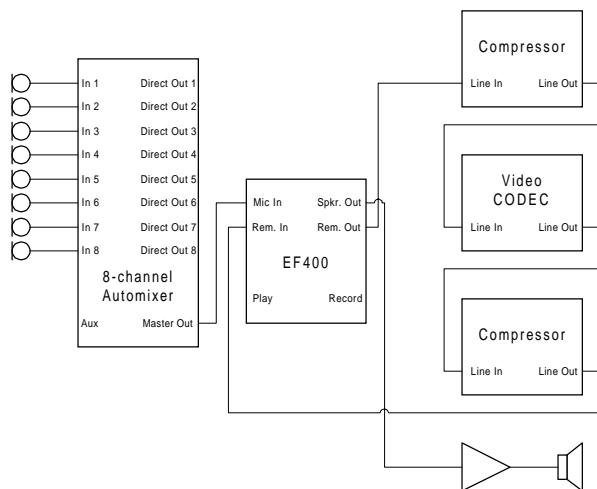

**Figure 3a:** Recommended placement of a dynamics processor in an EF400 system.

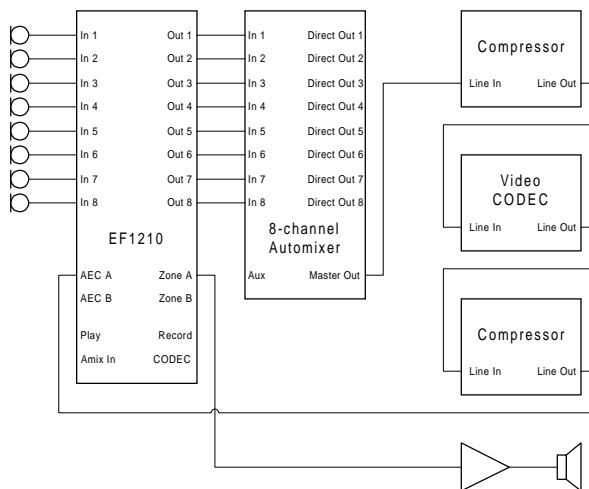

**Figure 3b:** Recommended placement of a dynamics processor in an EF1210 system.

Dynamics processors may complicate things for echo cancellers, depending on how drastic the curves are. While in the nonlinear parts of the curve, the processor will be changing gain fre-

quently. With very subtle amounts of dynamics processing, this may not affect the echo canceller. But to be on the safe side, we recommend placing the device outside the echo path.

## Feedback Reduction

A feedback reducer may be useful for reducing feedback in systems with both sound reinforcement and conferencing. Any combination of ASPI Digital echo cancellers and automatic mixers should work with a feedback reducer. Feedback reduction is not needed in systems without sound reinforcement.

The adaptive notch filters used to reduce feedback change the room response as they change frequency. The echo cancellers in the EF400 and EF1210 should not have trouble keeping up with these changes. However, if the sound reinforcement system is turned up near feedback, these adaptive notches may move around much more and affect the performance of the AEC. Also, some anti-feedback devices use pitch shifting to help reduce feedback, which is very bad for the AEC. Only use feedback reduction devices that don't have this pitch shifting feature, or can disable it.

## CONFIGURING THE MIXERS

When using an automatic mixer with the EF400, set the input phantom power and mic/line settings according to whatever is being connected to the mixer. The mixer should be configured for 10-20 dB off attenuation, and a moderate (300-600 ms) hold time. Last mic lock-on mode should be disabled.

When the EF1210 is used with automatic mixers, they should be set to line level with phantom power turned off. If the mixer only allows mic levels, pads may be used to bring the 0 dBu output of the EF1210 down to mic level. The other settings of the mixer are not critical, since the echo cancellation happens before the automatic mixer.

## EF1210 vs. EF400: WHICH IS BEST?

The EF400 and EF1210 are both versatile enough to work in the vast majority of situations. There are some circumstances, however, when one of these products is more appropriate than the other.

The EF400 is particularly suitable for:

- Small systems (four or less mics).
- Roll about videoconferencing.
- Large systems with strict budgets.
- Replacement of obsolete echo cancellers.
- Upgrading from internal video codec AEC.

We recommend using the EF1210 for:

- Large amounts of ambient noise.
- Rooms with very difficult acoustics or harsh gating requirements.
- Push-to-talk mics or direct outs.
- Large systems (more than four mics) where quality is at a premium.
- Room combining, or splitting one EF1210 between two rooms.

## NEED MORE HELP?

Whether you're new to ASPI Digital products, or trying them in new applications, you may have questions about how they should fit into your system. ASPI Digital's Applications Engineers are ready to help. We'll look at your situation and recommend a system that provides the performance you need, and fits your budget. Just call us at (800) 932-ASPI (2774) or drop us an email at [help@aspi.com](mailto:help@aspi.com). Or, if you like, you can fax us at (404) 892-2512 with a block diagram and detailed description of equipment in the room. We'll get back to you within a day or two with some recommendations that will provide the best quality conferencing possible. We may also be able to provide more specific guidelines for using the particular model of automatic mixer you are planning on using in your system.