

USING THE EF1210 WITH LECTROSONICS AUTOMATIC MIXERS

The combination of ASPI Digital echo cancellers and Lectrosonics automatic microphone mixers can make very powerful and economical conferencing systems. Conferencing systems of any size and function can be designed using a combination of products from Lectrosonics and ASPI Digital.

This document describes the recommended configurations of systems using ASPI Digital echo cancellers and Lectrosonics automatic microphone mixers for a variety of different products. The EF1210 is compatible with the AM8/AM8TC, AM8/4 and AM16 models of automatic mixers. The EF400 is compatible with the TA1 Line Level Adapter. The EF1210 does not need the TA1's functionality, but can be used with it as well.

If you are thinking of using an EF400 with a Lectrosonics automixer, we recommend using the EF1210 instead.

Designing the Room

The EF1210 is designed to provide maximum flexibility in the design of the sound system. The system can be designed almost as if the echo cancellation were not there. For instance, the design for a boardroom with zoned reinforcement should not change depending on whether it will have conferencing capabilities. You can design the system around the features and functionality of the Lectrosonics mixers, and then place the EF1210 echo canceller right after the microphones. Sample block diagrams of different types of systems are described below and shown in Figure 1.

Lectrosonics Automatic Mixers: Master vs. Slave Setting

Lectrosonics automatic mixers can either be set to a Master linking mode or Slave linking mode. In a system, whether multiple mixers are linked or not, exactly one Master should always be present. If multiple mixers are linked, all other mixers should be set to Slave mode. One mixer needs to be set to Master mode so that the mixer can collect all NOM signals from itself and from any Slave mixers connected to it and decide the automatic attenuation accordingly.

EF1210 - No Sound Reinforcement

When using the EF1210, one EF1210 is needed for each AM8 or AM8/4. Two EF1210s could also be used with each AM16. The mixers may be linked, and the output of the mixers is sent directly to the video codec. The mixer connected to the codec should be in "Master" mode, so that all mics are sent to the codec. All other mixers that are linked to the Master should be in "Slave" mode. The output of the codec should be sent to all EF1210s as an AEC reference. The zone output of one of the EF1210s can be used to provide the remote audio to the amplifier and loudspeakers.

EF1210 with Sound Reinforcement

When the EF1210 is used in a sound reinforcement system, the automatic mixers can still be linked in a similar way to a system without sound reinforcement. The automatic mixer connected to the codec should be in Master mode so that a mix of all microphones is sent to the remote end. All other mixers should be set for "Slave" linking so that a mix of each zone's

microphones can be treated separately. The AM16 automatic matrix mixer is a good choice for sound reinforcement because of its matrix mixing capabilities. A matrix mixer (the size depends on how many mixers are used) can send the appropriate mix of microphones, program audio, and remote audio to each zone's loudspeakers. Since the AM16 has full crosspoint gain, it may be used to provide different levels of reinforcement between different zones. The matrix should also provide a mix of all mics to the codec.

Note that the AEC reference inputs to the EF1210 do not include the sound reinforcement speech for each zone. The AEC reference should only contain program audio and remote speech.

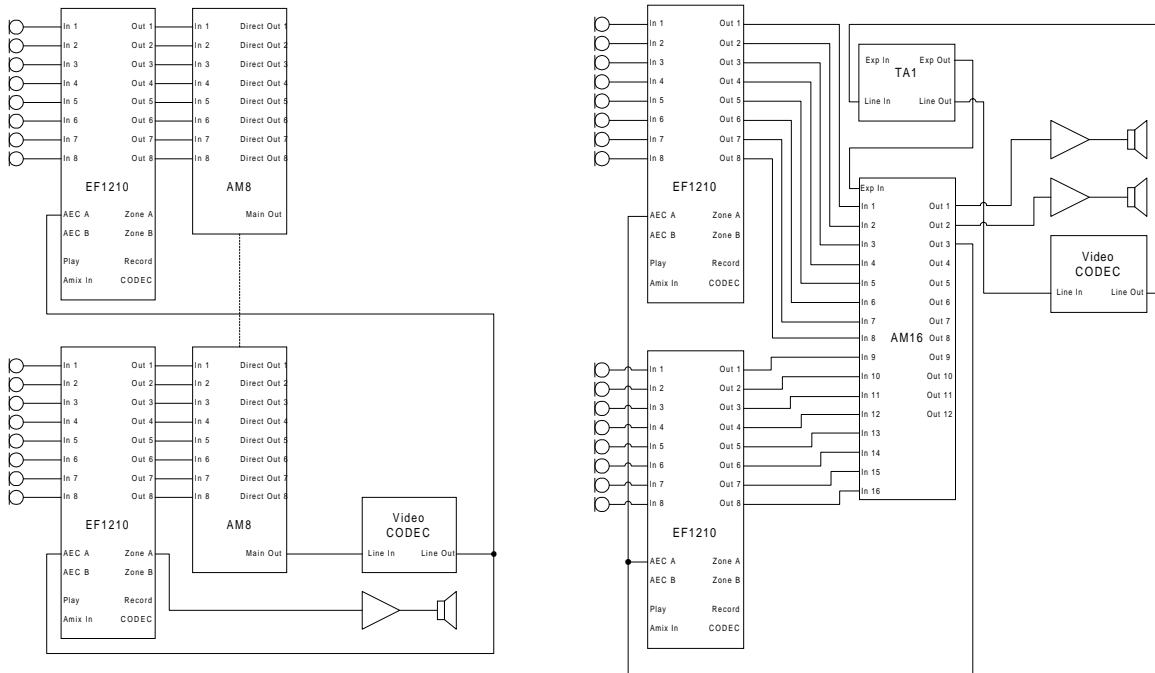

Figure 1a: EF1210 and AM8 without sound reinforcement. **Figure 1b:** EF1210 and AM16 with sound reinforcement.

Splitting the EF1210

The EF1210 may be split into two separate rooms using the two AEC reference inputs. This may be used to provide an economical solution for two adjacent rooms, or for room combining

applications. For this application, one AM8/4 is used. The figure below shows how one AM8/4 can be used to split a single EF1210 between two totally independent rooms.

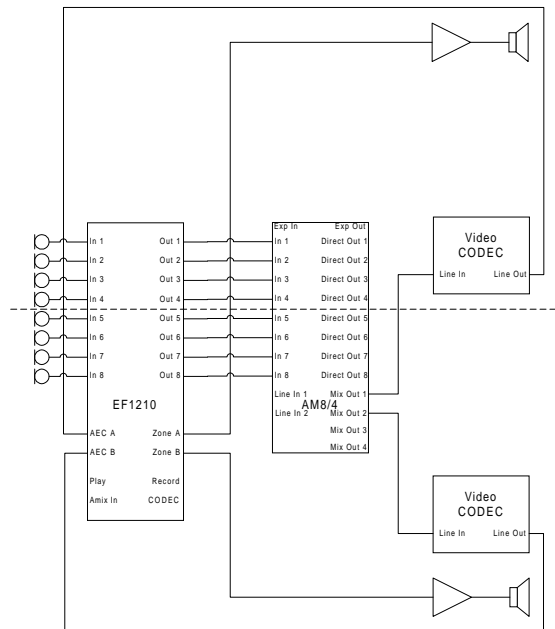

Figure 2: Using the EF1210 with one AM8/4 for two different rooms.

It is possible to use the EF1210 in zoned reinforcement systems with less than 8 mics in each zone. In this case, however, it is not necessary to use both AEC reference inputs. All the echo cancellers should get the same reference, which is the remote speech and program audio. The sound reinforcement signals should not be used as part of the reference. Since all the channels are using the same reference, it is possible to send any channel to any mixer. For example, in a system with 16 mics and four zones, one AM16 could be used with two EF1210s. This configuration is shown in Figure 3. In a larger system (24 mics with four zones), one AM16 and one

AM8 could be used with three EF1210s. Because all the channels are using the same reference, it doesn't matter that some mixers are getting channels from two different EF1210s.

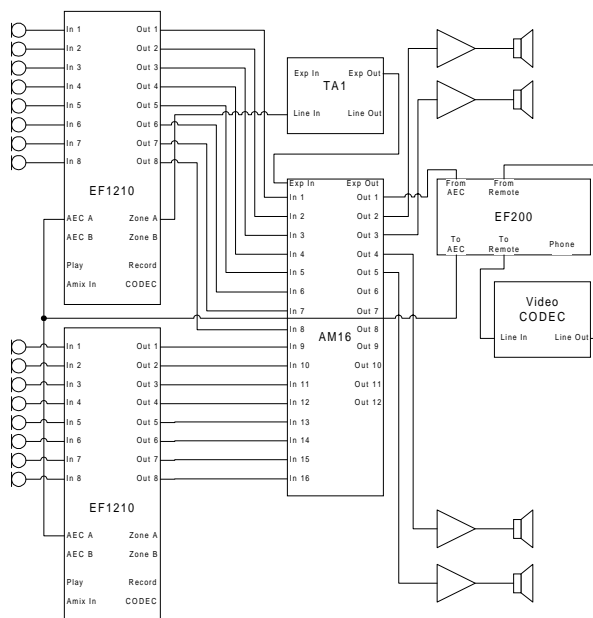

Figure 3: Using the EF1210 with 1 AM16 for 4 zones in a zoned reinforcement system.

SPECIAL EQUIPMENT AND APPLICATIONS

Using Push-To-Talk Microphones

For optimal AEC performance, the push-to-talk switch should not mute the microphone element directly. Rather, it should provide a contact closure or TTL signal to the logic controls of the automatic mixer. If built-in switches are required, microphones such as the Shure MX392, Crown PCC-170SWO, and the Beyerdynamic MPC67RC models are recommended. These provide a separate logic signal, but do not mute the microphone element directly when the switch is toggled. In many cases (such as with ceiling mounted microphones), an external switch can be connected directly to the mixer's logic port.

Alternatively, the mute functions on the EF1210 as well as the Lectrosonics automatic mixers may be used to provide push-to-talk or other muting functionality through RS-232 control.

Using Direct Outs

Since the EF1210 provides echo cancellation on each channel, each of these direct outs will have the echo removed. Generally, the EF1210 and the AM8 or AM16 are recommended if direct outs are needed.

Dynamics Processing

A dynamics processing device, such as the Compressor/Leveller function on the AM8 automatic mixer, may be useful for providing constant levels to and from the room. The Compressor-

or/Leveller function can be turned on when being used with the EF1210 since the echo cancellation comes before the automatic mixing.

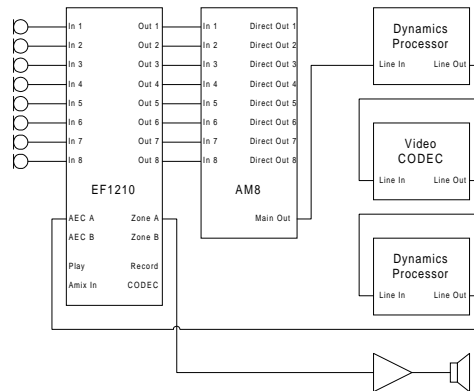

Figure 4: Recommended placement of an external dynamics processor in an EF1210 system.

Feedback Reduction

A feedback reducer such as the one in the DSP4/4 Digital Audio Processor may be useful for reducing feedback in systems with both sound reinforcement and conferencing. Any combination of ASPI Digital echo cancellers and Lectrosonics mixers should work with the DSP4/4. Feedback reduction is not needed in systems without sound reinforcement.

The adaptive notch filters used to reduce feedback change the room response as they change frequency. The echo canceller in EF1210 should not have trouble keeping up with these changes. However, if the sound reinforcement system is turned up near feedback, these adaptive notches may move around much more and affect the performance of the AEC. The adaptive notch filters on the DSP4/4 can be locked once the feedback is located to prevent the filters from wandering in this case. Also, some anti-feedback devices use pitch shifting to help reduce feedback, which is very bad for the AEC. Only use feedback reduction devices that don't have this pitch shifting feature, or can be disabled.

CONFIGURING THE MIXERS

AM8/AM8TC

On the input channels to the AM8/AM8TC, set the input phantom power and mic/line settings according to whatever is being connected to the mixer. For the EF1210, these should all be set to LINE with Phantom Power turned off.

The following settings are recommended for the EF1210 for each channel input on the AM8.

Table 1: Recommended AM8 DIP Switch Settings per Channel Input for use with the EF1210

Switch #	1	2	3, 4
Setting	Down	Up	Up, Up

Table 1: Recommended AM8 DIP Switch Settings per Channel Input for use with the EF1210

Switch Function	Auto	Phantom Power Off	0 dB input preamp gain for line level sources
-----------------	------	-------------------	---

When using mixers with EF1210s, the mixer connected to the CODEC should generally be in Master mode. When multiple mixers are linked with the EF1210, the other mixers should be set for Slave mode.

The Compressor/Leveller can be either enabled (in the IN position) or disabled (OUT) when the AM8 is being used with the EF1210.

AM8/4

On the input channels to the AM8/4, set the input phantom power and mic/line settings according to whatever is being connected to the mixer. For the EF1210, these should all be set to LINE with Phantom Power turned off. Also, when using the AM8/4 with the EF1210, each input should be in automatic mode which can be set using the LecNet software.

When using mixers with EF1210s, the mixer connected to the CODEC should be in Master mode. When multiple mixers are linked with the EF1210, the other mixers should be set for Slave mode.

AM16

For the EF1210, the Phantom Power dip switches should be in the off position and the Gain setting on each mic/line input should be set to 0 dB gain (line level).

When using mixers with EF1210s, the mixer connected to the CODEC should generally be in Master mode. When multiple mixers are linked, the others may be set for Slave mode.

EF1210 vs. EF400: WHICH IS BEST?

The EF400 and EF1210 are both versatile enough to work in the vast majority of situations. There are some circumstances, however, when one of these products is more appropriate than the other.

The EF400 is particularly suitable for:

- Small systems (four or less mics).
- Roll about videoconferencing.
- Replacement of obsolete echo cancellers.
- Upgrading from internal video codec AEC.
- Gating automatic mixers.

We recommend using the EF1210 for:

- Large amounts of ambient noise.
- Rooms with very difficult acoustics or harsh gating requirements.
- Push-to-talk mics or direct outs.
- Large systems (more than four mics) where quality is at a premium.
- Room combining, or splitting one EF1210 between two rooms.
- Gain sharing automatic mixers.

NEED MORE HELP?

Whether you're new to ASPI Digital products, or trying them in new applications, you may have questions about how they should fit into your system. ASPI Digital's Applications Engineers are ready to help. We'll look at your situation and recommend a system that provides the performance you need, and fits your budget. Just call us at (800) 932-ASPI (2774) or drop us an email at help@aspi.com. Or, if you like, you can fax us at (404) 892-2512 with a block diagram and detailed description of equipment in the room. We'll get back to you within a day or two with some recommendations that will provide the best quality conferencing possible.