



## USING THE EF400 AND EF1210 WITH IED AUTOMATIC MIXERS

The combination of ASPI Digital echo cancellers and IED automatic microphone mixers can make very powerful and economical conferencing systems. Conferencing systems of any size and function can be designed using a combination of products from IED and ASPI Digital.

This document describes the recommended configurations of systems using ASPI Digital echo cancellers and IED automatic microphone mixers for a variety of different products. The EF400 and EF1210 are compatible with the IED 4400 and 4800 automatic mixers.

### DESIGNING THE ROOM

The EF400 and EF1210 are designed to provide maximum flexibility in the design of the sound system. The system can be designed almost as if the echo cancellation were not there. For instance, the design for a boardroom with zoned reinforcement should not change depending on whether it will have conferencing capabilities. You can design the system around the features and functionality of the IED mixers, and then place the echo canceller right after the mics (in the case of the EF1210), or right in front of the codec (in the case of the EF400). Sample block diagrams of different types of systems are described below and shown in Figure 1.

#### EF1210 - No Sound Reinforcement

When using the EF1210, one EF1210 is needed for each automatic mixer. The output of the mixer is sent directly to the video codec. The output of the codec should be sent to the EF1210 as an AEC reference. The zone output of the EF1210 can be used to provide the remote audio to the amplifier and loudspeakers.

#### EF400 - No Sound Reinforcement

When using the EF400 with IED automixers, simply connect the output of the mixer to the mic/line input of the EF400. Only one EF400 is needed for the system. The remote output of the EF400 is sent to the video codec.

#### EF1210 with Sound Reinforcement

When the EF1210 is used in a sound reinforcement system, a matrix mixer (the size depends on how many mixers are used) can send the appropriate mix of microphones, program audio, and remote audio to each zone's loudspeakers. A matrix with full crosspoint gain may be useful to provide different levels of reinforcement between different zones. The matrix should also provide a mix of all mics to the codec.

Note that the AEC reference inputs to the EF1210 do not include the sound reinforcement speech for each zone. The AEC reference should only contain program audio and remote speech.

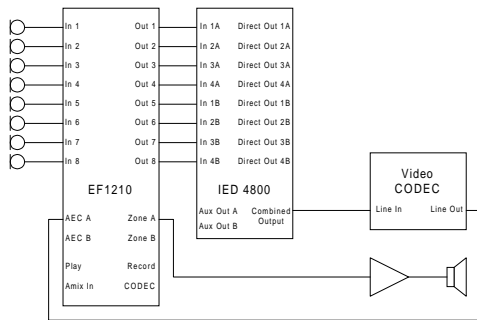

**Figure 1a:** EF1210 and IED 4800 without sound reinforcement.

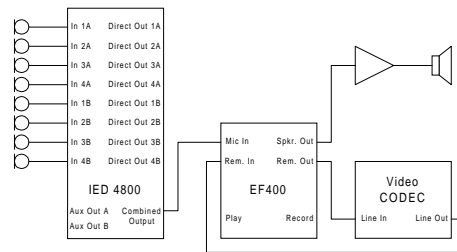

**Figure 1b:** EF400 and IED 4800 without sound reinforcement.

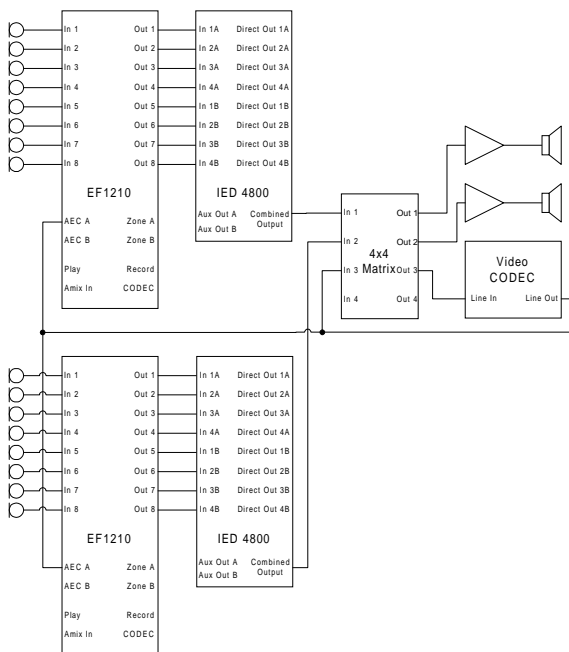

**Figure 1c:** EF1210 and IED 4800 with sound reinforcement.

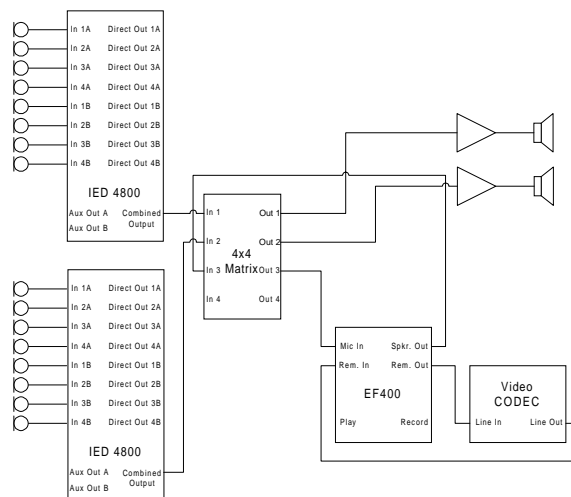

**Figure 1d:** EF400 and IED 4800 with sound reinforcement.

### EF400 with Sound Reinforcement

The configuration of a sound reinforcement and conferencing system with an EF400 is very similar to an EF1210 system. The only major difference is that the EF400 is placed between the matrix and the video codec, while the EF1210 is placed between the microphones and the mixers. The matrix provides the appropriate mix of microphones, remote audio, and program audio to the loudspeakers and video codec.

### Splitting the EF1210

The EF1210 may be split into two separate rooms using the two AEC reference inputs. This may be used to provide an economical solution for two adjacent rooms, or for room combining applications. If the EF1210 is split equally, one 4800 may be used. If one of the rooms has more than four mics (say one room has 6 and the other has 2), one 4400 and one 4800 may be

used. The figure below shows how one 4800 could be configured to split a single EF1210 between two totally independent rooms.

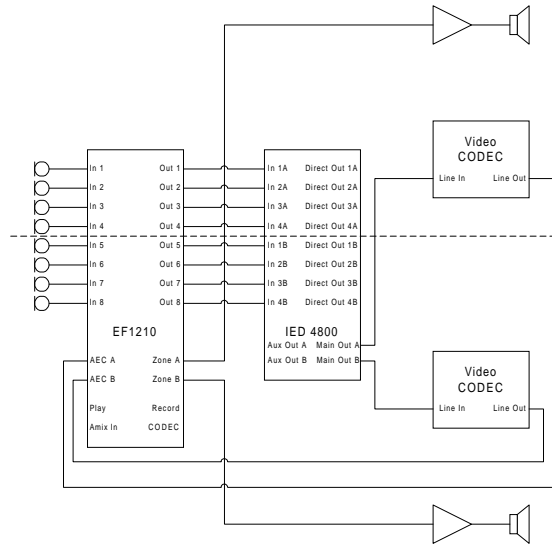

**Figure 2:** Using the EF1210 with 1 IED 4800 for two different rooms.

It is possible to use the EF1210 in zoned reinforcement systems with less than 8 mics in each zone. In this case, however, it is not necessary to use both AEC reference inputs. All the echo cancellers should get the same reference, which is the remote speech and program audio. The sound reinforcement signals should not be used as part of the reference.

## GETTING OPTIMUM ECHO CANCELLATION WITH THE EF400

Automatic mixers present a challenge to single channel echo cancellers. They effectively cause constant changes in the acoustic properties of the room by turning microphones on and off. The echo canceller must adapt quickly and constantly to keep up with these changes. This is the case when using an automatic mixer with the EF400. The EF400 adapts very quickly and therefore works better with automatic mixers than any other single channel echo canceller. However, some precautions may enhance the performance of the EF400 when used with an automatic mixer, especially in difficult rooms.

### Avoid Last Mic Lock-On

Last mic lock-on should be turned off (so that all mics are off after their release time has expired). This is required in most situations for the EF400 to work properly.

### Use less off attenuation.

When off attenuation is infinite, the AEC sees no echo in the room when all of the microphones are off. When a mic is activated, there is suddenly a great deal more echo to cancel. Using the 22.5 dB off attenuation option on IED mixers makes these changes less drastic.

### Isolate microphones from loudspeakers.

Providing isolation between microphones and loudspeakers has two benefits. First, it reduces the echo received by the echo canceller, which makes its job easier. When using automatic

mixers, it also makes the loudspeaker signal less likely to cause microphones to activate. This is important because it reduces the likelihood that random microphones will activate from the loudspeaker, changing the echo path while only the far end is talking. Reducing the number of microphone activations caused by the loudspeaker signal will improve the echo canceller's performance.

### **Provide remote reference channel to mixer.**

IED's Discriminator circuit on the 4400 and 4800 provides a way to prevent the loudspeaker signal from activating microphones. If an extra mixer channel is available, the remote (far end) signal can be fed to a line level input. This input should then be permanently muted, using the Force Off terminals on the Remote Connector. When the remote end talks, the muted channel will be activated. The Discriminator circuit will prevent other channels in the mixer from activating on the same signal, but will allow local speech in the room to activate microphones.

Since the EF1210 performs echo cancellation on the individual channels before mixing, it is not affected by the automatic mixer. Therefore, these precautions are not necessary (although it is always beneficial to provide good isolation between loudspeakers and microphones).

## **SPECIAL EQUIPMENT AND APPLICATIONS**

### **Using Push-To-Talk Microphones**

For optimal AEC performance, the push-to-talk switch should not mute the microphone element directly. Rather, it should provide a connection to the Force Off terminals on the Remote Connector of the automatic mixer. If built-in switches are required, microphones such as the Shure MX392, Crown PCC-170SWO, and Beyerdynamic MPC67RC models are recommended. These provide a separate logic signal, but do not mute the microphone element directly when the switch is toggled. In many cases (such as with ceiling mounted mics), an external switch can be connected directly to the mixer's logic port.

When using push-to-talk mics in a system with the EF400, the "Mute In" logic function should be reconfigured to simply inhibit gating. This prevents the mics from being activated, rather than muting them entirely. When an EF1210 is used, this modification is optional. In general, the EF1210 will have better performance with push-to-talk microphones than the EF400.

Alternatively, the mute functions on the EF1210 may be used to provide push-to-talk or other muting functionality through RS-232 control.

### **Using Direct Outs**

If direct outs of each microphone channel are needed for recording or other purposes, the EF1210 is recommended. Since the EF1210 provides echo cancellation on each channel, each of these direct outs will have the echo removed. The EF400 may be used, but the direct outs from the automatic mixer may have audible acoustic echo since the echo cancellation is performed after the mix. Generally, the EF1210 and the 4800 are recommended if direct outs are needed.

### **Dynamics Processing**

A dynamics processing device may be useful for providing constant levels to and from the room. For instance, compression may be used on the output of a codec (or multiple codecs in a bridge) to provide consistent levels from various remote systems. A dynamics processing device may be used with any combination of EchoFree echo cancellers and IED automatic mixers.

Dynamics processors may complicate things for echo cancellers, depending on how drastic the curves are. While in the nonlinear parts of the curve, the processor will be changing gain frequently. With very subtle amounts of dynamics processing, this may not affect the echo canceller. But to be on the safe side, we recommend placing the dynamics processor outside the echo path.

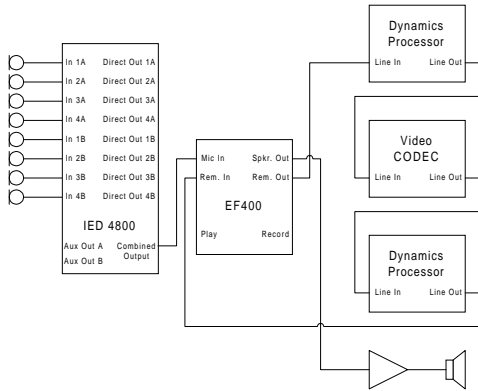

**Figure 3a:** Recommended placement of a dynamics processor in an EF400 system.

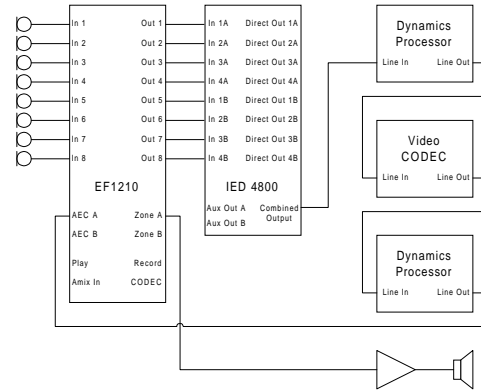

**Figure 3b:** Recommended placement of a dynamics processor in an EF1210 system.

## Feedback Reduction

A feedback reducer may be useful for reducing feedback in systems with both sound reinforcement and conferencing. Any combination of ASPI Digital echo cancellers and IED mixers will work with a feedback reducer. Feedback reduction is not needed in systems without sound reinforcement.

The adaptive notch filters used to reduce feedback change the room response as they change frequency. The echo cancellers in the EF400 and EF1210 should not have trouble keeping up with these changes. However, if the sound reinforcement system is turned up near feedback, these adaptive notches may move around much more and affect the performance of the AEC.

## CONFIGURING THE MIXERS

### IED 4400 or 4800

When using the 4400 or 4800 with the EF400, set the line level or microphone level jumper on each input channel according to the type of microphone (or other device) being used on each channel. For the EF1210, these jumpers should all be set to line level with phantom power turned off.

We strongly recommend the following jumper settings on the 4400 or 4800 when used with the EF400. These settings are also recommended (but not as crucial) for the EF1210.

**Table 1:** Recommended 4400 or 4800 Jumper Settings

Jumper/Switch Function	Auto/Manual Switch	Last Mic On and Onput	Release Time	Gated Off Attenuation
Setting	Auto	Neither	0.5 seconds	22.5 dB

The release time is not critical to the performance of the AEC. The mixer connected to the EF400 should contain a mix of all microphones so that all microphones in the system are sent to the remote site.

## EF1210 vs. EF400: WHICH IS BEST?

The EF400 and EF1210 are both versatile enough to work in the vast majority of situations. There are some circumstances, however, when one of these products is more appropriate than the other.

The EF400 is particularly suitable for:

- Small systems (four or less mics).
- Roll about videoconferencing.
- Large systems with strict budgets.
- Replacement of obsolete echo cancellers.
- Upgrading from internal video codec AEC.

We recommend using the EF1210 for:

- Large amounts of ambient noise.
- Rooms with very difficult acoustics or harsh gating requirements.
- Push-to-talk mics or direct outs.
- Large systems (more than four mics) where quality is at a premium.
- Room combining, or splitting one EF1210 between two rooms.

## NEED MORE HELP?

Whether you're new to ASPI Digital products, or trying them in new applications, you may have questions about how they should fit into your system. ASPI Digital's Applications Engineers are ready to help. We'll look at your situation and recommend a system that provides the performance you need, and fits your budget. Just call us at (800) 932-ASPI (2774) or drop us an email at [help@aspi.com](mailto:help@aspi.com). Or, if you like, you can fax us at (404) 892-2512 with a block diagram and detailed description of equipment in the room. We'll get back to you within a day or two with some recommendations that will provide the best quality conferencing possible.